

T & M system solutions for broadcasting

Centralized transmitter room – systems with the R&S®SFE100 broadcast test transmitter



Years of
Driving
Innovation



ROHDE & SCHWARZ

The production and development solution for TVs, STBs, tuners and mobile TV receivers

At a glance

Centralized multesignal generation for production, research and development as well as quality assurance for broadcast receivers and their components

High-quality multesignals for all common TV standards and a number of broadcasting standards

System solutions centered around the single-standard R&S®SFE100 broadcast test transmitter provide high-quality multesignals for all common TV standards and a number of broadcasting standards. There are many possible applications in production, development labs and quality assurance (QA).

Outstanding qualities

The R&S®SFE100 is at the core of the system concept. It combines baseband generation, RF modulation and power amplification capabilities in a flat box that occupies only one height unit (HU). Its compact design, outstanding reliability and low power consumption make the test transmitter ideal for the above applications.

Modular system for customized solutions with diverse test scenarios

Very specific systems are needed to handle the requirements posed by different applications. Working with the Rohde&Schwarz sales organization and the Rohde&Schwarz system integrators around the globe, it is possible to build customer-oriented system solutions based on a modular system. The signal quality and output power of the overall system are ensured through the use of high-quality RF components. Baseband signals with user-selectable contents for video, audio and other data make it possible to use the system in a wide variety of locations across the globe and in many different customer test scenarios.

Easy-to-use configuration management

The intuitive operating concept of the single-standard test transmitter (already successfully implemented in the R&S®SFU broadcast test system) along with additional control software for the overall system make the configuration management dependable and easy-to-use.



Application

A multisignal generation system contains multiple test transmitters capable of generating analog and digital RF signals. The individual signals are combined by using filters and couplers to form a single output signal. At the output of the multisignal generation system, this signal is supplied to a network for distribution to the test stations.

The main applications of this type of system involve the generation of test signals that are needed during production of TV and sound broadcast receivers and their components. They are also used in research and development and QA labs. Unlike mobile broadcast receivers, no return channel is needed with broadcast receivers since one-to-multipoint transmission is used.

Use in production facilities

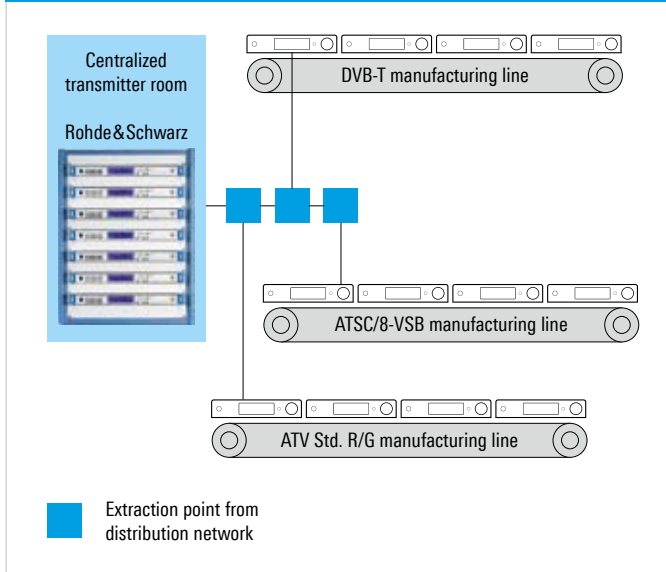

Multisignal generation for use in production facilities

In production facilities for panels, LCD televisions and mobile TV receivers or their individual components, multiple production lines are usually operated in parallel. Depending on what is required, these lines will produce devices that handle different TV and sound broadcasting standards.

Instead of costly multistandard modulators for each of these production lines (which have to be reconfigured every time to meet different requirements), a multisignal generation system represents a better, more cost-effective choice in many cases. For testing, the receivers can be set to specific channels which then continuously provide the necessary standard via the distribution system.

Multisignal generation in research and development and in quality assurance

Real RF signals have to be used for testing TV and sound broadcast receivers during their various stages of development. Some examples of interim stages include tuner development, decoder and interface implementation as well as functional testing for different standards. The development teams for a specific product usually work in parallel.

Instead of using dedicated signal generators at the individual workstations, deploying a centralized multisignal generation system is usually more cost-effective.

R&D and quality assurance

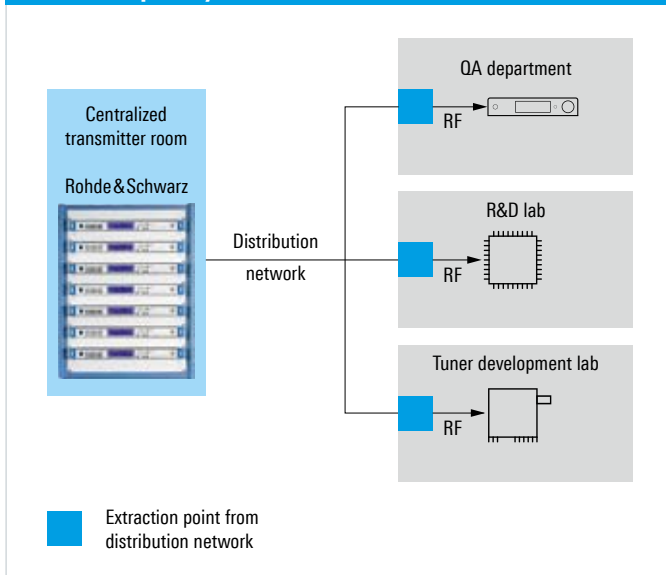

Main features and benefits

Main features

- Multisignal generation for all common analog and digital broadcasting standards
- Compact (customer-specific) system design
- Low power consumption for efficient continuous operation
- High signal output levels without additional broadband amplifiers
- Customer-specific adaptation of baseband signals
- Simple configuration management (also via remote control)
- Efficient, cost-effective redundancy concept

Multisignal generation for all common analog and digital broadcasting standards

The system consists of a number of R&S®SFE100 broadcast test transmitters providing different transmission standards. The test transmitter is flat and occupies only a single height unit (HU). It is specially designed for use in production applications where generation of seamless test signals is required. Costly synchronization of the signal generators with a production cycle is not required. Benefits that truly pay off in production applications include outstanding signal quality, dependability and an economical price/performance ratio.

Compact (customer-specific) system design

This type of centralized transmission system consists of a number of components, including test transmitters as well as RF and software components. The modular system concept makes it possible to build customer-specific systems that meet individual requirements with regard to the standards, output power, channel occupation, test signals, failsafety and control facilities.

With the R&S®SFE100 as the basis of the system, the main components (signal generator, modulator and amplifier) are combined in a single instrument. This means that the entire system will usually fit into a single rack.

Low power consumption for efficient continuous operation

Despite the many functions that are integrated into the R&S®SFE100, its power consumption is very low. A typical system with 10 channels has a total power consumption of only 1 kW. This serves as a basis for economical continuous operation in a production or development environment.

High signal output levels without additional broadband amplifiers

By using the integrated broadband amplifier provided in the R&S®SFE100, output power levels of up to a maximum of 134 dBuV (controllable) are supported. External broadband amplifiers – which are often the source of loss in signal quality – are thus usually not required as system components.

Customer-specific adaptation of baseband signals

A wide range of test signals is needed to handle different transmission standards, video and audio encoding standards and locally variable content. Besides test signal libraries from Rohde&Schwarz, custom baseband signals can also be integrated into the overall system to handle special requirements and test procedures on the customer's end.

Simple configuration management with control software and LAN integration

Many applications require the capability to configure the overall system using the system's control software via a LAN interface. Specifically, this must be done in order to ensure uniform test conditions and allow easy modification of the system configuration. The control software provides a graphical presentation of the current system status along with the capability to remotely modify the configuration from different workstations (R&D, production line).

Efficient, cost-effective redundancy concept

Existing systems used for centralized multisignal generation often require a dedicated spare device for each of the many different transmission standards.

However, the solution from Rohde&Schwarz offers a different concept. A single multistandard test transmitter can be used universally as part of the redundancy concept, and can be configured for each transmission standard. This reduces the investment expense needed to ensure dependable operation to a minimum.

Configuration

Rohde & Schwarz offers an all-in-one solution that allows centralized signal generation to meet customer-specific requirements. Installation of the distribution network is not part of the system solution.

Depending on the actual customer requirements, the system components will vary to suit the available budget and functionality needed. Rohde & Schwarz has local sales offices worldwide that can provide customer consultation. Moreover, by working together with our system integrators, the local offices can develop flexible system concepts.

The following figure shows the main components and tasks handled by the system:

System configuration



R&S®SFE100 broadcast test transmitter, available for: DVB-T/H, -C, -S, -S2, 8VSB, J.83B, ISDB-T, T-DMB/DAB, DTMB, DirecTV, MediaFLO™, B/G, D/K, I,M/N, L

Customer-specific baseband signals and control software:

Test pattern and live video



Remote control and configuration



Coupling network components and installation equipment:

couplers, filters, mounting racks, cables, connectors, matching pads, etc.

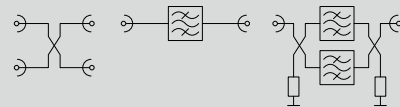

Redundancy solution

Spare units: R&S®SFE with flexible option management

Service options: service frame agreement

Service you can rely on

- ! In 70 countries
- ! Person-to-person
- ! Customized and flexible
- ! Quality with a warranty
- ! No hidden terms

Rohde & Schwarz

Rohde & Schwarz is an independent group of companies specializing in electronics. It is a leading supplier of solutions in the fields of test and measurement, broadcasting, radiomonitoring and radiolocation as well as secure communications. Established 75 years ago, Rohde & Schwarz has a global presence and a dedicated service network in over 70 countries. Company headquarters are in Munich, Germany.

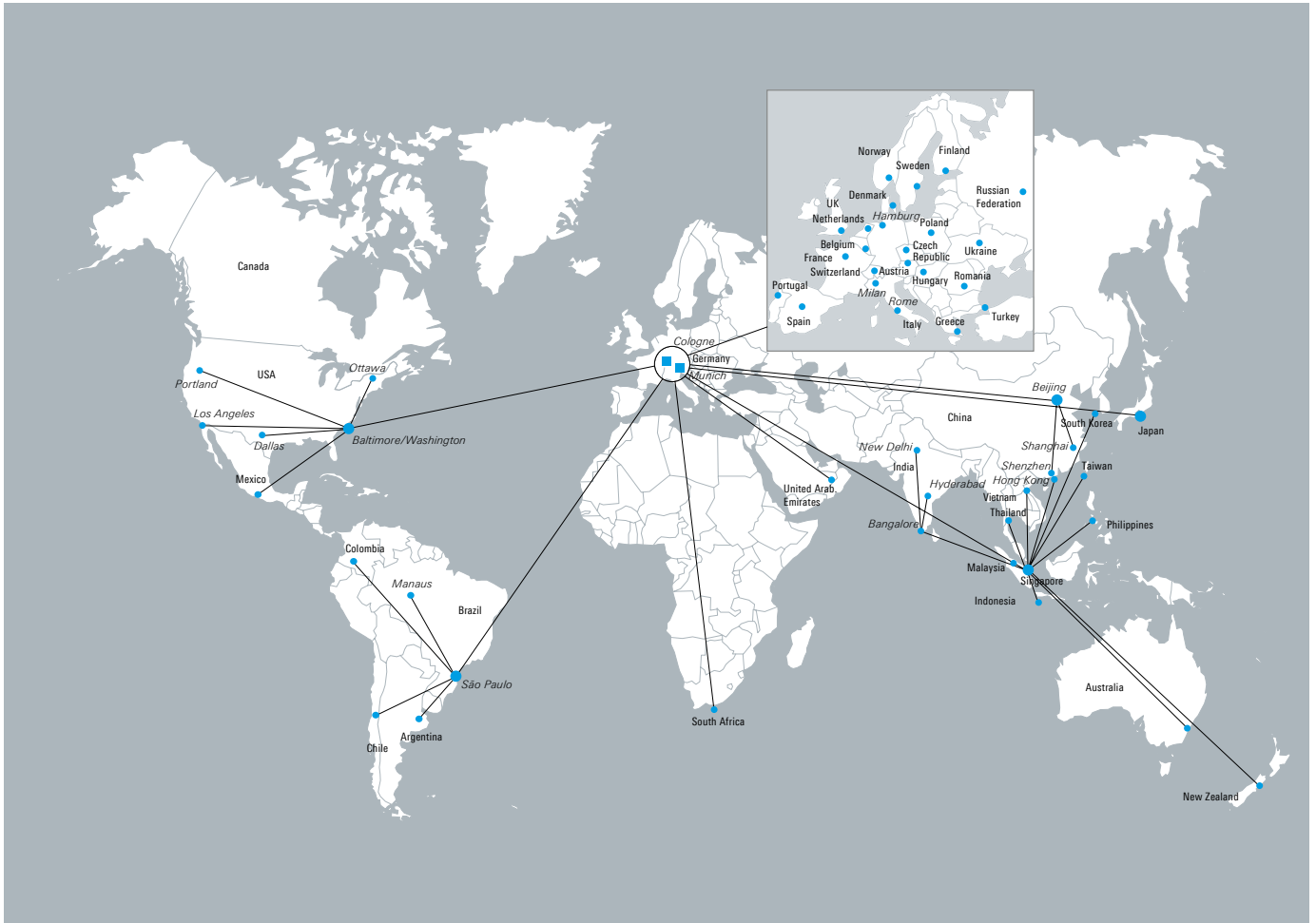

Rohde & Schwarz GmbH & Co. KG

Europe, Africa, Middle East +49 1805 12 42 42* or +49 89 4129 137 74
customersupport@rohde-schwarz.com
North America 1-888-TEST-RSA (1-888-837-8772)
customer.support@rsa.rohde-schwarz.com
Latin America +1-410-910-7988
customersupport.la@rohde-schwarz.com
Asia/Pacific +65 65 13 04 88
customersupport.asia@rohde-schwarz.com
www.rohde-schwarz.com

R&S® is a registered trademark of Rohde & Schwarz GmbH & Co. KG
Trade names are trademarks of the owners
PD 5214.0160.31 | Version 01.00 | June 2008 | R&S®SFE100
Data without tolerance limits is not binding
Subject to change | Printed in Germany (as/sv)

*0.14 €/min within German wireline network; rates may vary from other networks (wireline and mobile) and countries